

GoldStar

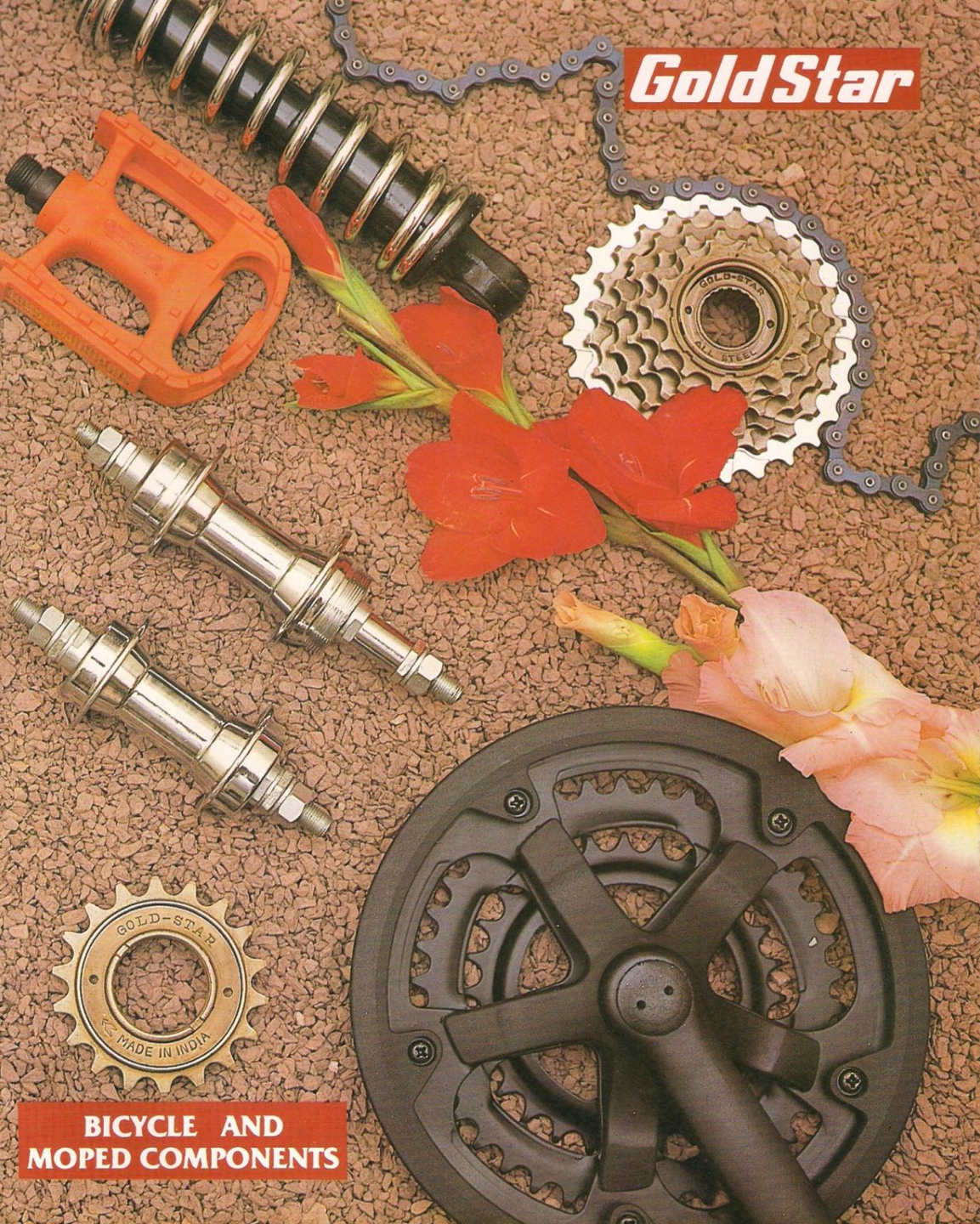

**BICYCLE AND
MOPED COMPONENTS**

GOLD STAR range of Bicycle & Moped parts was launched by Jain brothers a decade ago. Today, the company has achieved commendable performance in the international bicycle & moped markets. The credit goes to the business acumen, hardwork and continuous vigilance on the quality of the products manufactured in this company. The best available raw materials are used in the manufacturing of components with the latest techniques. The company is fully equipped with latest quality control measures along with a hard working team for servicing trade enquiries not only of own manufactured products but also of other engineering goods.

We feels that in the race of excellence, there is no finishing line. Come and join us, we guarantee lifelong relationship.

JAIN BROTHERS

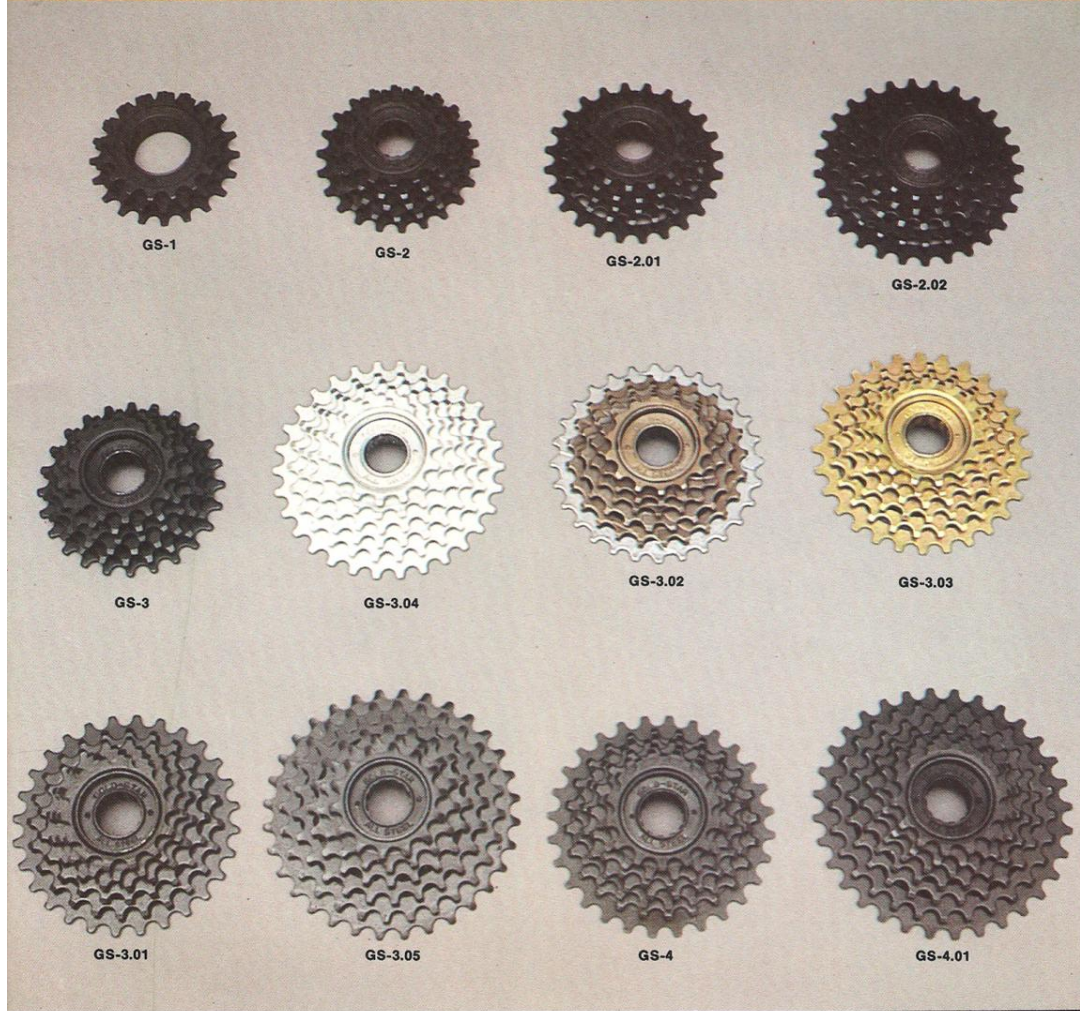

MULTISPEED FREEWHEELS : 1/2"×3/32" full steel balls.

Finish - black or to order.

GS-1 (3 SPEED) 1/2"×1/8" or 1/2"×3/32" (A) 16-18-20T
(B) 16-19-22T

GS-2 (5 SPEED) 14-16-18-20-22T (14-22T)

GS-2.01 (5 SPEED) (A) 14-16-18-21-24T (14-24T)
(B) 14-16-19-22-26T (14-26T)

GS-2.02 (5 SPEED) 14-17-20-24-28T (14-28T)

GS-3 (6 SPEED) 14-16-18-20-22-24T (14-24T)

GS-3.04 (6 SPEED) 14-17-20-23-26-30T (14-30T) Z.P. finish.

GS-3.02 (6 SPEED INDEX TYPE) 14-16-18-21-24-28T (14-28T)
Brown/black finish 28T sprocket BCP.

GS-3.03 (6 SPEED) 14-16-18-21-24-28T (14-28T) Golden finish.

GS-3.01 (6 SPEED) 14-16-18-21-24-28T (14-28T).

GS-3.05 (6 SPEED INDEX TYPE) Twisted Teeth 14-17-21-24-28-32T (14-32T)

GS-4 (7 SPEED) 14-16-18-20-22-24-28T (14-28T)

GS-4.01 (7 SPEED) 14-16-18-21-24-28-32T (14-32T)





GS-5



GS-5.01



GS-5.02



GS-5.03



GS-5.04



GS-5.05



GS-5.06



GS-5.07



GS-5.08



A



B



C



GS-5.09

SINGLE SPEED FREEWHEELS

1/2" x 1/8" Half or full steel balls. 34.8mm (1.370") x 24 TPI BSCY or 34.7mm x 1mm ISO-Metric thread, Golden Finish.

- GS-5 16 Teeth
- GS-5.01 17 Teeth
- GS-5.02 18 Teeth
- GS-5.03 19 Teeth
- GS-5.04 20 Teeth
- GS-5.05 21 Teeth
- GS-5.06 22 Teeth
- GS-5.07 23 Teeth
- GS-5.08 24 Teeth
- GS-5.09 (SPROCKET) 1/2" x 1/8" or 1/2" x 3/32", 1.370 x 24 TPI

- (A) Silky finish.
- (B) Inner view of half ball freewheels.
- (C) Inner view of full ball freewheels.

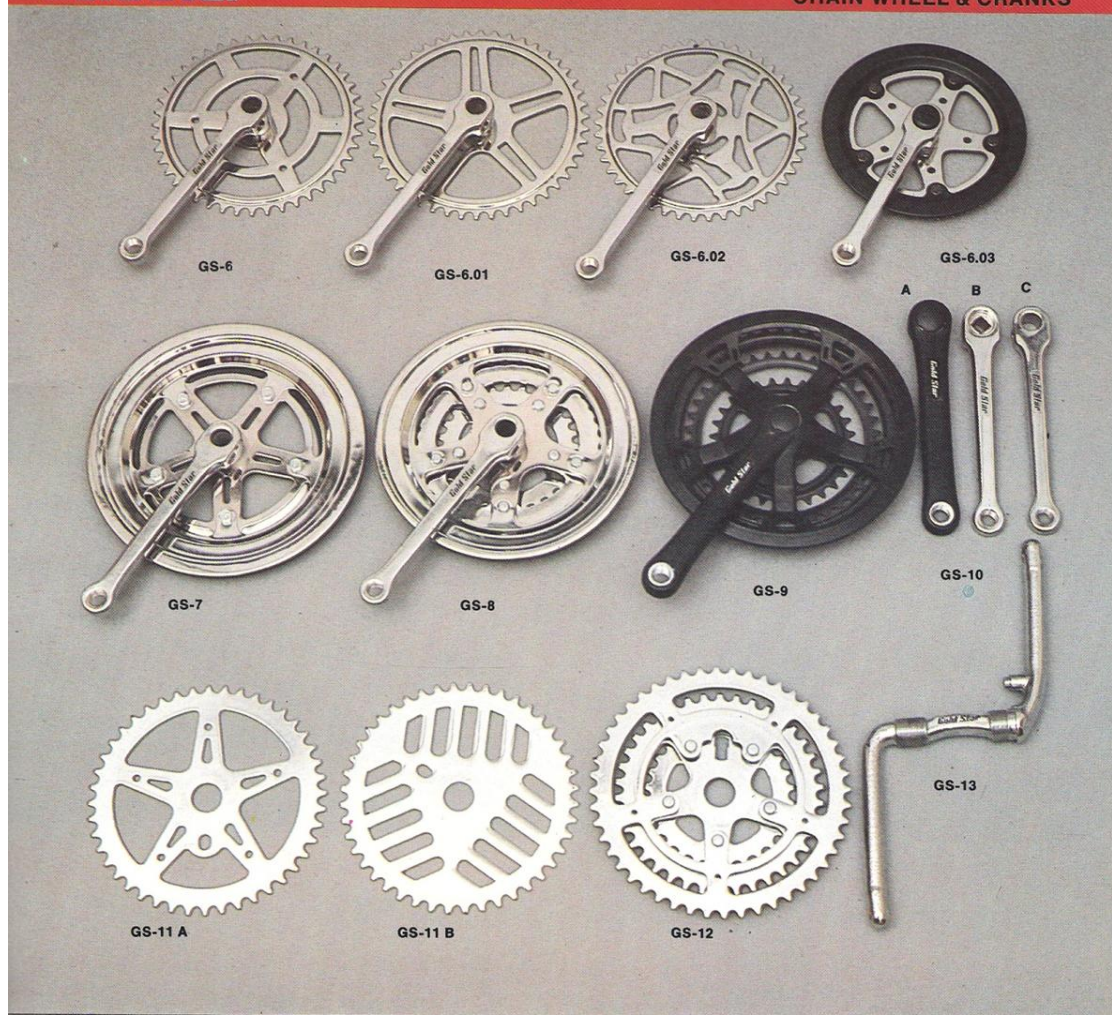

CHAIN WHEEL & CRANKS

PITCH×TOOTH THICKNESS	Standard	Threading	Cotter Pin Hole MM	B.B. Hole MM
1/2"×1/8" or 1/2"×3/32"	English	9/16" (14.28mm) ×20 TPI WW	9.5	15.9
	French	14MM×1.25 Pitch ISO-Metric	9.0	16.0
	Italian	9/16"×20 TPI WW	9.0	16.0

GS-6 (JAPAN CUT) : 44 Teeth×6½"/6¾"/7" Crank c to c coterless BCP/ Powder coated, with or without three holes. Other sizes 28T, 32T, 36T, 40T, 46T, 48T, 52T. Crank sizes : 4", 4½", 5", 5½", 6", 6½", 6¾" & 7". C to C.

GS-6.01 (ITALIAN CUT) : 46/48 Teeth×6¾". 1/2"×1/8" or 1/2"×3/32". Crank sizes : 6", 6½", 6¾" & 7".

GS-6.02 (BIRDHEAD CUT) : 44/46/48 Teeth. Cranks 6½"/6¾"/7".

GS-6.03 (ITALIAN CUT) : 40 Teeth×5½" Crank coterless/coterless with Black/White/BCP chainguard.

GS-7 (DOUBLE CHAINWHEEL) : Coterless/Coterless, with/without chainguard 1/2"×3/32"×40T-48T & 42T-52T Crank sizes : 6½" & 6¾".

GS-8 (TRIPLE CHAINWHEEL) : 1/2"×3/32"×28T-38T-48T. Crank sizes : 6½" & 6¾".

GS-9 (TRIPLE CHAINWHEEL) : Plastic coated with coterless spider crank 1/2"×3/32"×28T-38T-48T. Crank size : 6¾" (170mm).

GS-10 (SPARE CRANK) : "A" 6¾" Plastic coated left crank. "B" Coterless. BCP/Powder coated left crank length to order. "C" Coterless. Available in British/French/Italian standard BNCP/Powder coated, length to order.

GS-11 (CHAINWHEEL) : Chainwheel 44 Teeth 1/2"×1/8" for one piece crank BNCP/Powder coated Model GS-11 "A" or GS-11 "B".

GS-12 (TRIPLE CHAINWHEEL) : For one piece crank 1/2"×3/32"×28T-38T-48T

GS-13 : ONE PIECE CRANK - Hot forged, 5½" or 6½" BNCP.

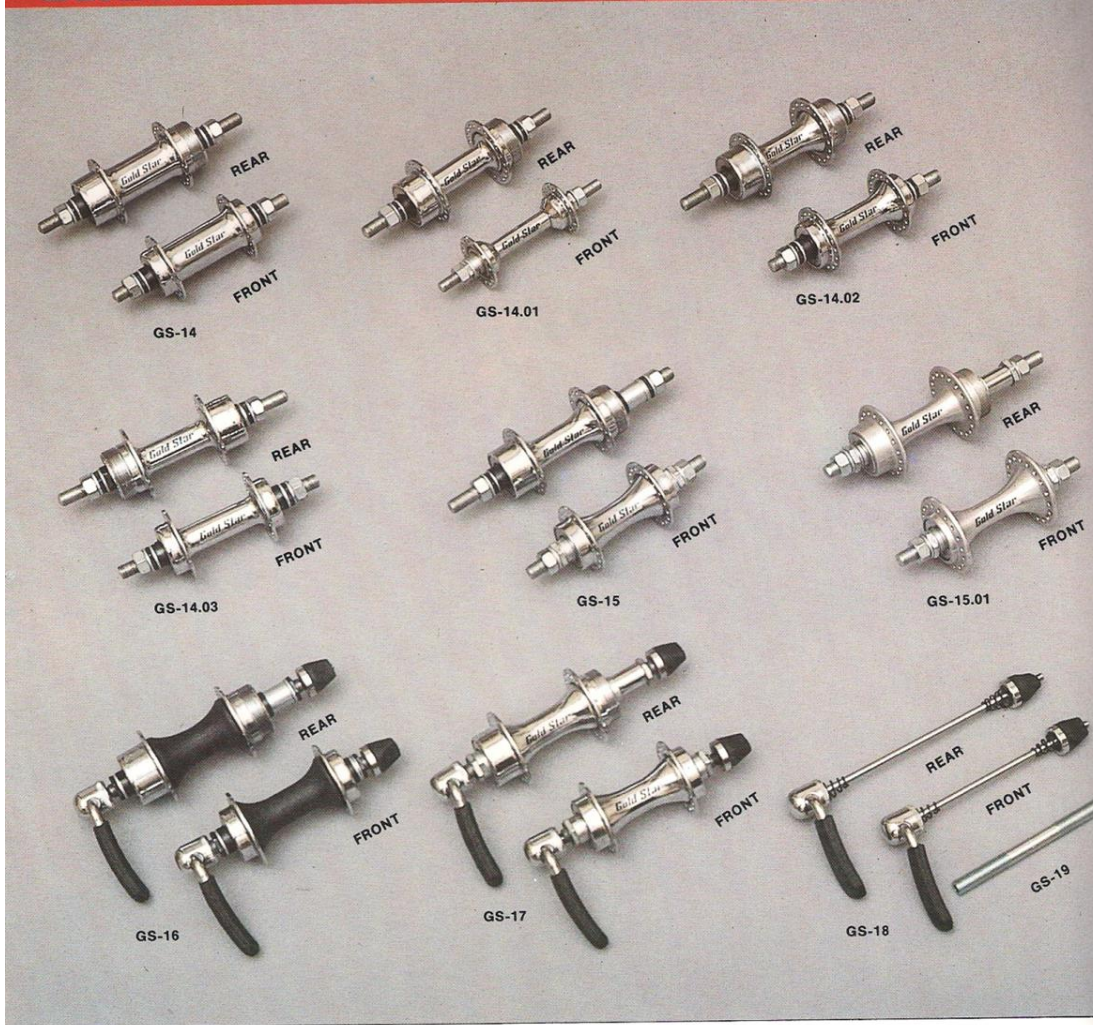

HUBS

GS-14 (PHILLIPS) : Front : Thick barrel, open ends, BCP hub axles 3/8"×5½". Rear : Thick barrel, open ends, BCP hub axle 3/8"×6½". Spoke holes 20/28/32/36/40H×14G. Thread on flange 1.370×24 TPI BSCY spoke holes for 10g & 12g to order.

GS-14.01 (RALEIGH) : Front : Thin barrel, open ends, BCP hub axles 5/16"×5½"/6". Rear : Thin barrel, open ends, BCP hub axle 3/8"×6½". Spoke holes : 20/28/32/36/40g, 1.370"×24 TPI BSCY or 34.7mm×1mm pitch ISO-Metric thread.

GS-14.02 (OVAL) : Front : open ends, BCP, hub axles 3/8"×5½". Rear : hub axle 3/8"×6½". Spoke holes : 32/36/40H×14g.

GS-14.03 (BMX) : Front : 3/8"×5½" hub axles, open ends BCP. Rear : 3/8"×6½" hub axles. Spoke holes : 14g×36H, 24 TPI BSCY Thread.

GS-15 (OVAL MULTISPEED) : MTB hubs oval type hub axes. Front : 3/8"×140mm across nuts 96/98/100mm Rear : 3/8"×165/170/175mm across nuts 126/128/130mm Thread : 34.8mm×24 TPI BSCY. Spoke hole 14G×36H.

GS-15.01 (OVAL MULTISPEED) : Made of Aluminium Alloy.

GS-16 (OVAL MTB QUICK RELEASE) : Barrel plastic coated in assorted colours. Front : 3/8"×102/106/108mm, across nuts 96/98/100mm Rear : 3/8"×136mm Thread : 34.8mm×24 TPI.

GS-17 (QUICK RELEASE OVAL) : Front : 3/8"×102/106/108mm, Across nuts 96/98/100mm Rear : 3/8"×136mm Thread : 34.8mm×24 TPI.

GS-18 (QUICK RELEASE SKEWER) : Front : 5mm×121/126/130mm Rear : 5mm×155/160mm.

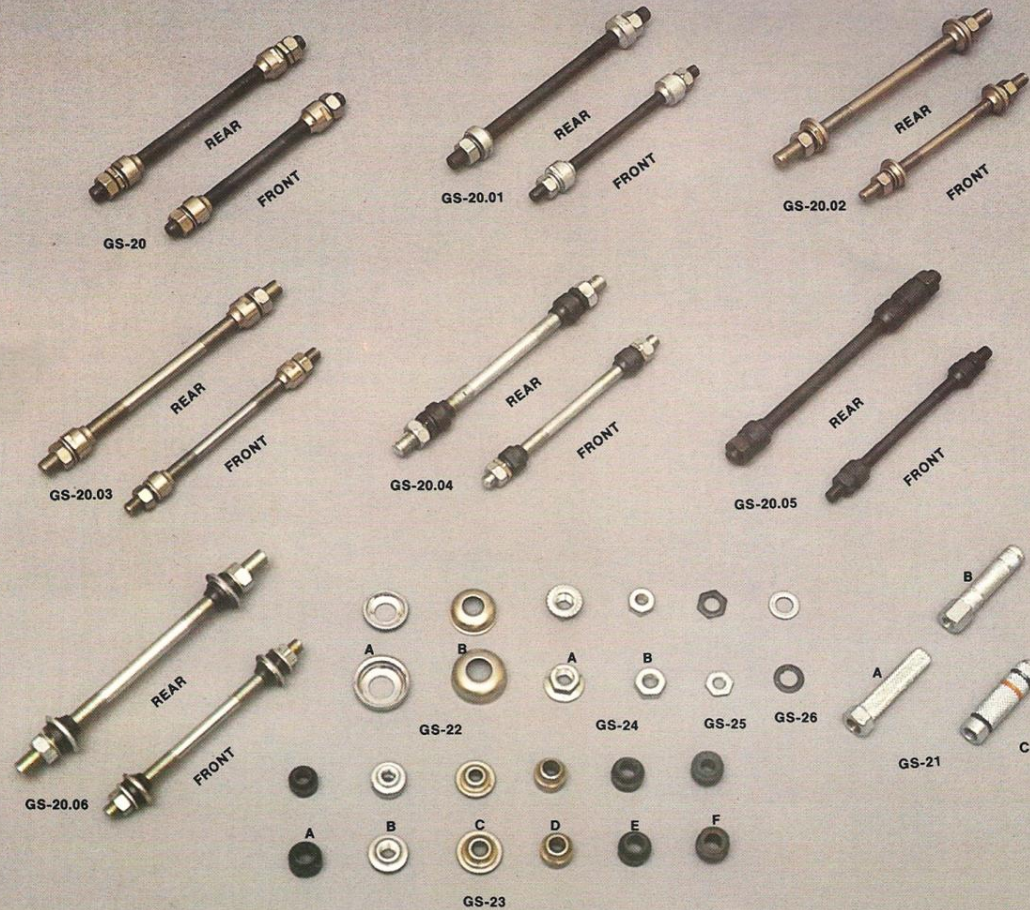

HUB AXLES : With cones, nuts, washers, with or without check nuts. Plain or grooved, Otto Black/NP/ZP to order. 26 TPI BSCY thread.

GS-20 (PHILLIPS) : F. $3/8" \times 5\frac{1}{2}"/6"$ R. $3/8" \times 6\frac{1}{2}"/7"$.

GS-20.01 (RALEIGH) : F. $5/16" \times 5\frac{1}{2}"/6"$ R. $3/8" \times 6\frac{1}{2}"/7"$.

GS-20.02 ("A" MODEL) : F. $5/16" \times 5\frac{1}{2}"/6"$ R. $3/8" \times 6\frac{1}{2}"/7"$.

GS-20.03 (AMERICAN) : F. $5/16" \times 5\frac{1}{2}"/6"$ R. $3/8" \times 6\frac{1}{2}"/7"$.

GS-20.04 (FRENCH) : F. 8mm \times 140mm R. 9.5mm \times 165mm. Grooved, Threads : 1mm pitch ISO-METRIC.

GS-20.05 (MULTISPEED) : F. $5/16"/3/8" \times 5\frac{1}{2}"/6"$ R. $3/8" \times 6\frac{1}{2}"/7"$ with spacer for MTB & Racing bikes.

GS-20.06 (HUB BRAKE SPINDLE) : F. $5/16" \times 5\frac{1}{2}"/6"$ R. $3/8" \times 6\frac{1}{2}"/7"$ with dust cap.

GS-21 (HUB STEPS) : "A", "B" or "C" Model, $5/16"$ or $3/8" \times 26$ TPI.

GS-22 (HUB CUPS) : "A" without collar "B" with collar F. ϕ 23.8/24.5/25/29.2 mm R. ϕ 29/29.2/29.5/30/30.5 mm finish to order.

GS-23 (HUB CONES) : Phillips/Raleigh/Model "A"/American/French.

GS-24 (HUB NUTS) : Flanged/Hexagonal type $3/8" / 5/16"$.

GS-25 : Check Nuts for Hub Axles $3/8" / 5/16"$.

GS-26 : Washers for Hub Axles $3/8" / 5/16"$.

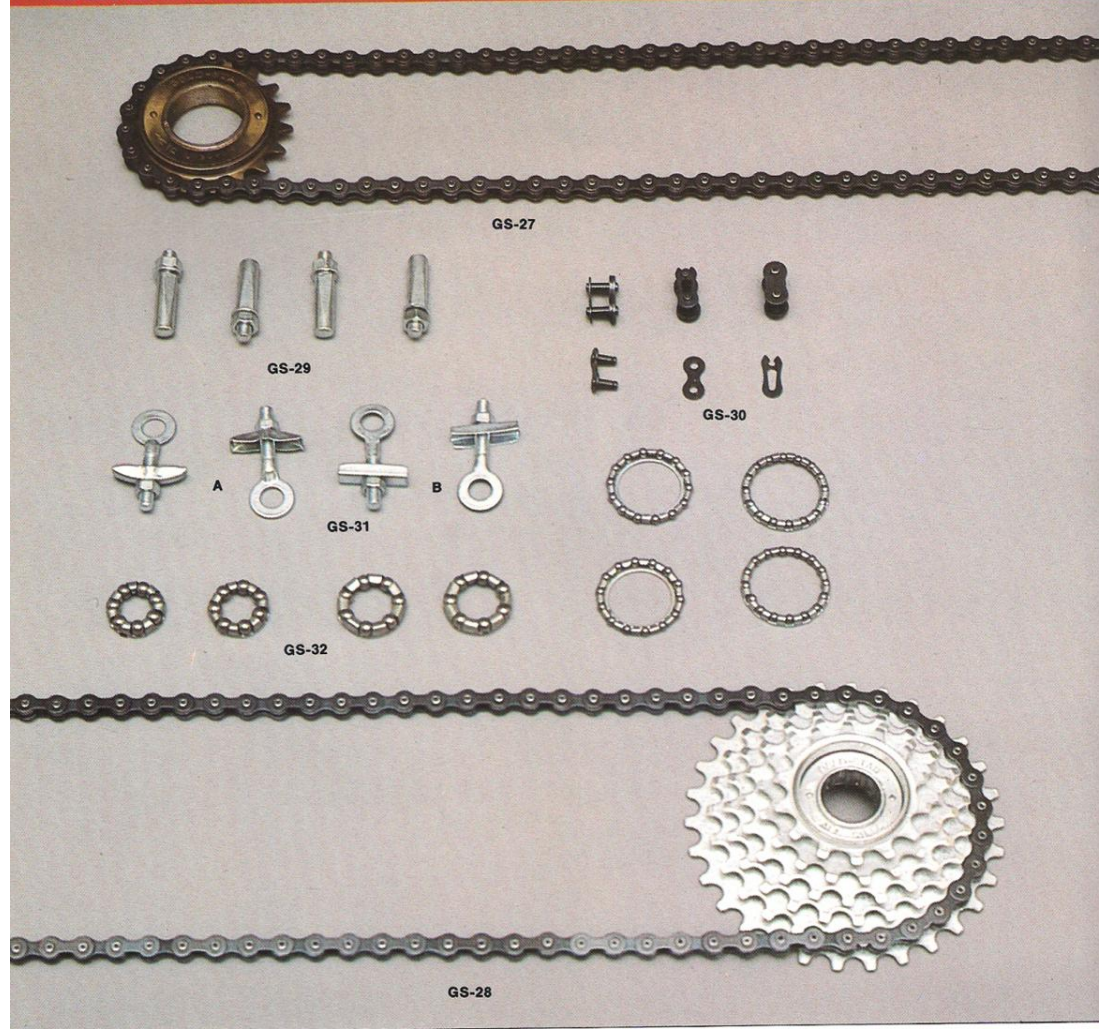

CHAINS

GS-27 : 1/2" X 1/8" : Roller chains made from medium carbon steel, heat treated in black-blue finish in 72/78/92/104/108/112/114 Links or in 150 Mtrs. rolls.

GS-28 : 1/2" X 3/32" Roller chains made from medium carbon steel, heat treated in black-blue finish in 108/112/116 Links or in 150 Mtrs. rolls.

SIZE	ISO NO.	Pitch MM	Roller Dia MM	Width bet. Inner Plates MM	Width over Bearing Pin MM	Measuring Load	Breaking Load
1/2" X 1/8"	081	12.7	7.75	3.30 Min.	10.2 Max.	13 Kg.	820 Kg.
1/2" X 3/32"	082	12.7	7.75	2.38 Min.	8.2 Max.	13 Kg.	1000 Kg.

GS-29 (COTTER PINS) : Complete with nuts & washers in ZP finish, Threads-6.7mm X 26 TPI or 6mm X 1mm pitch sizes : ϕ 3/8" / 9.3mm / 9.0mm Length : 4 1/42 mm.

GS-30 (CHAIN LINKS) : Chain connecting links spring clip type.
GS-31 (CHAIN ADJUSTER) **GS-31 A** : Closed ends for 3/8".

GS-31 B : Open ends for 3/8", 11mm & 12mm. Threads : 1/4" X 26 TPI or 6mm X 1mm pitch, ZP finish.

GS-32 (BALL RETAINERS) : 3/16" X 7 balls for Front hub, 1/4" X 7 balls for rear hub, 1/4" X 7/9 balls for B.B. Fittings, 5/32" X 14/16 balls for fork fittings.

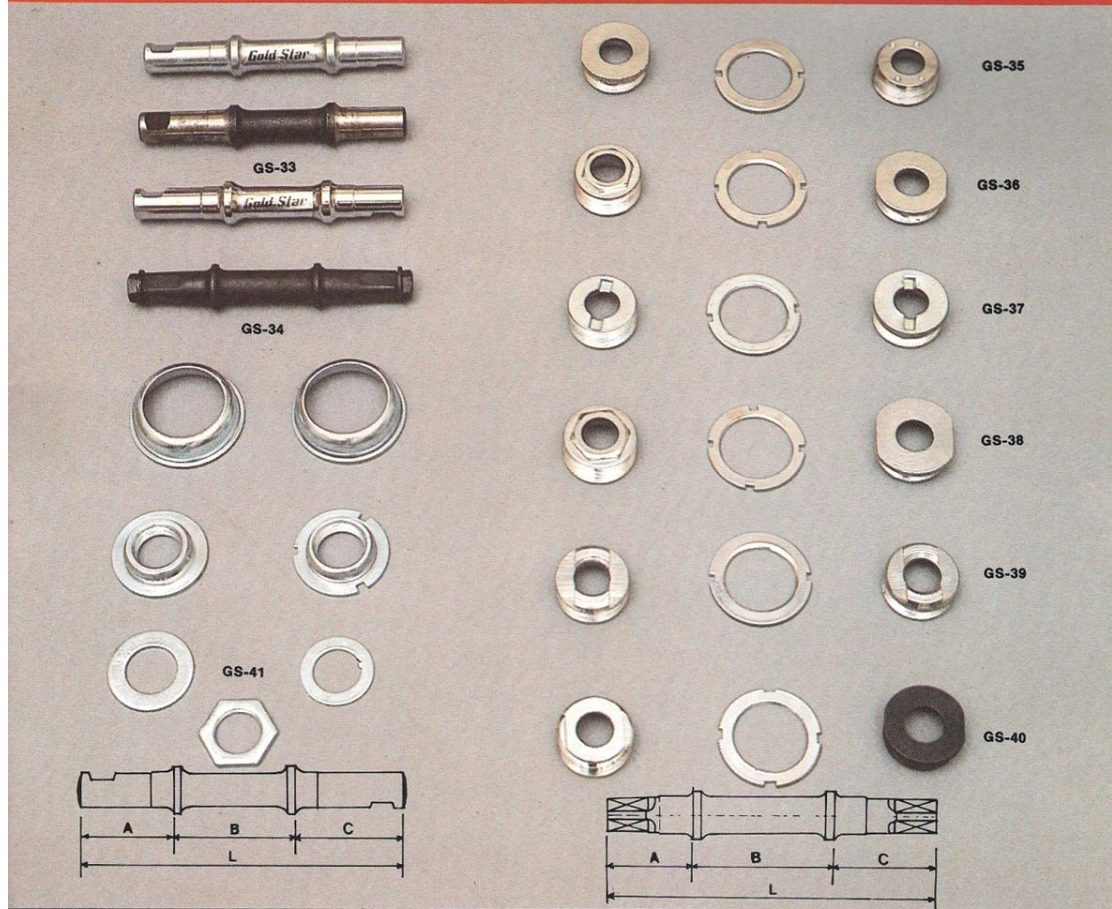

B. B. AXLE: Made of low carbon steel, hardened & ground. In Otto black/ZP/BNCP/& Black & Ground finish.

GS-33 : COTTER PIN TYPE Dimensions : In mm.

Model No.	Item Code	Left A	Centre B	Right C	Total Length L	Dia D
2-C	GS-33.01	37	54	46	136	
A-8	GS-33.02	34.5	61.5	45	141	
SLR	GS-33.03	36	55	47	138	
Y-3	GS-33.04	40	52	49	141	MIN 15.65
Y-4	GS-33.05	34	52	44	130	MAX. 15.80
Y-5	GS-33.06	36	54	46	136	
Y-15	GS-33.07	34	54	42	130	
Y-16	GS-33.08	36	57	46	139	
Y-18	GS-33.09	37	51	50	138	
MINI	GS-33.10	51	56	51	158	
MEXICAN	GS-33.11	45	55	45	145	
N° 69	GS-33.12	45	57	45	147	
FRENCH-1	GS-33.13	37	56	44	137	MIN. 15.85
FRENCH-2	GS-33.14	35	58	45	138	MAX. 15.95

GS-34 : COTTERLESS (BOLT TYPE) Axle in black finish.

	Item Code	A	B	C	L	Bracket Width
3 - U	GS-33.16	35	55	40.5	130.5	70
5 - P	GS-33.17	32	55	35	122	70

B. B. CUPS

GS-35 (PHILLIPS TYPE): 1.37"×24 TPI RH & LH, **GS-35.01:** 34.8mm×24 TPI RH & RH, **GS-35.02:** 35mm×24 TPI RH & RH, **GS-35.03:** 35.5×24 TPI RH & RH, **GS-35.04:** 36mm×24 TPI RH & RH BSCY threads. BCP/ZP/Otto black finish to order.

GS-36 (HEXAGONAL FRENCH): 35mm×1mm pitch, **GS-36.01:** 36mm×1mm pitch metric RH & RH threads, BCP.

GS-37 (PHILLIPS TYPE NEW): Cold forged with slot type key ZP finish.

GS-38 (ITALIAN TYPE): 1.37"×24 TPI RH & LH, **GS-38.01:** 34.8mm×24 TPI RH & RH, **GS-38.02:** 36mm×24 TPI RH & RH WW threads.

GS-39 (RALEIGH): 34.8mm×26 TPI RH & LH, **GS-39.01:** 34.8×24 TPI RH & LH thread. BCP/ZP/Otto black finish.

GS-40 (FRENCH TYPE): 35mm×1mm pitch RH & RH Metric thread. **GS-40.01:** 34.8mm×24 TPI RH & RH, BCP, collar black finish.

GS-41 (B.B. PARTS FOR O.P.C.): Set of 7/9 pcs. Ball racer cups 51.5 mm dia, ball racer cones RH 15/16"-24 UNS-RH, LH 7/8"-24 UNS-LH, Lock Nut 7/8"-24 UNS-LH.

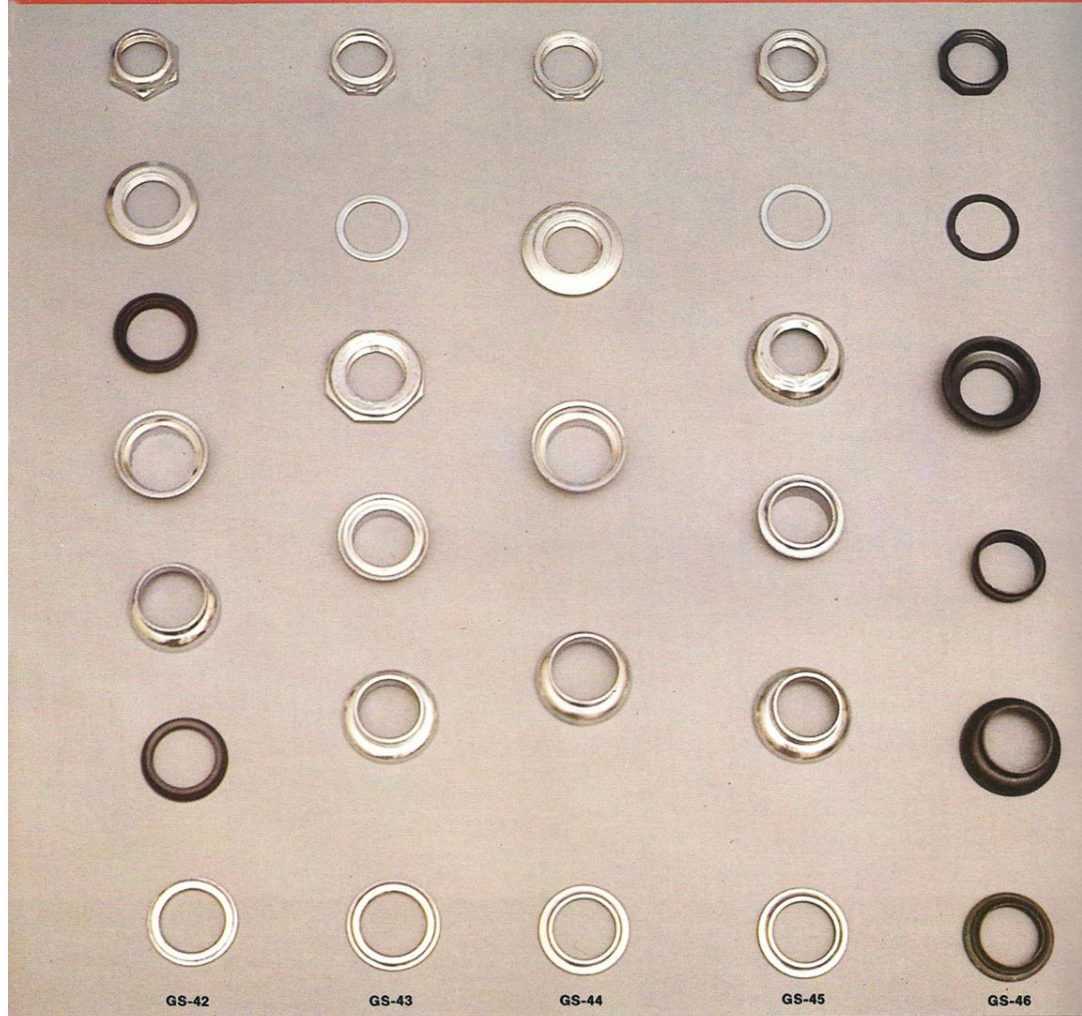

FORK FITTINGS

GS-42 (PHILLIPS TYPE) : Set of 7 pcs. Polished & B.C.P., ball racer rings self finish/otto black. Ball size : 1/8" (3.17mm) Thread : 1" (25.4mm) × 24 TPI BSCY.

GS-43 (RALEIGH TYPE) : Set of 5/6 pcs. Polished & B.C.P., Ball size : 5/32" (3.97mm) Thread sizes : 1" (25.4mm) × 26 TPI BSCY or 1" × 24 TPI BSCY Washer ZP.

GS-44 (FRENCH TYPE) : Set of 5/6 pcs. Polished & B.C.P., Ball size : 5/32" (3.97mm) Thread 25mm × 1mm pitch ISO Metric.

GS-45 (ITALIAN TYPE) : Set of 6 pcs. Polished & BCP, Washer ZP, 1" (25.4mm) × 24 TPI BSCY with or without Ball retainers.

GS-46 (SWEDISH TYPE) : Set of 6 pcs. SWEDISH/ZEBRA type. Ball size : 5/32" or 3/16" Thread 1" (25.4mm) × 24 TPI BSCY. Black/BCP finish Ball retainers to order.



PEDALS: Threading sizes : 14.28mm (9/16")×20 TPI WW/12.7mm (1/2")×20 TPI UNF/14mm×1.25mm pitch ISO-METRIC threads.

GS-47 : Plastic pedals with reflectors in assorted colours & sizes - A, B, F & I : 98mm & C, D, E & G : 95mm, H with/without steel balls.

GS-48 A : Plastic pedals for kid bikes 86mm. GS-48B bush type without steel balls.

GS-49 : Fine diamond, black rubber, without reflectors 3½" or 4".

GS-49.01 : Fine diamond with reflectors.

GS-50 : Curved fine diamond PVC blocks with reflectors, strecher strips, winged side flange, size 3¾" (95mm).

GS-50.01 : Diamond cut PVC blocks without reflectors, size : 4". One sided nuts ribbed/without ribbed.

GS-51 : Diamond cut rubber blocks without reflectors, size : 4".

GS-51.01 : Diamond cut rubber blocks without reflectors, size : 4".

GS-52 : Monoblock rubber pedals for exerciser. Size : 4".

GS-53 : Steel frame without reflectors, size - 98mm.

GS-53.01 : Steel frame heavy duty without reflectors, size - 95mm.

GS-54 : Rat trap steel frame with reflectors, size - 98mm.

GS-54.01 : Steel frame with reflectors, with center plate, size - 98mm.

GS-54.02 : Steel frame heavy duty with reflectors, size - 95mm.

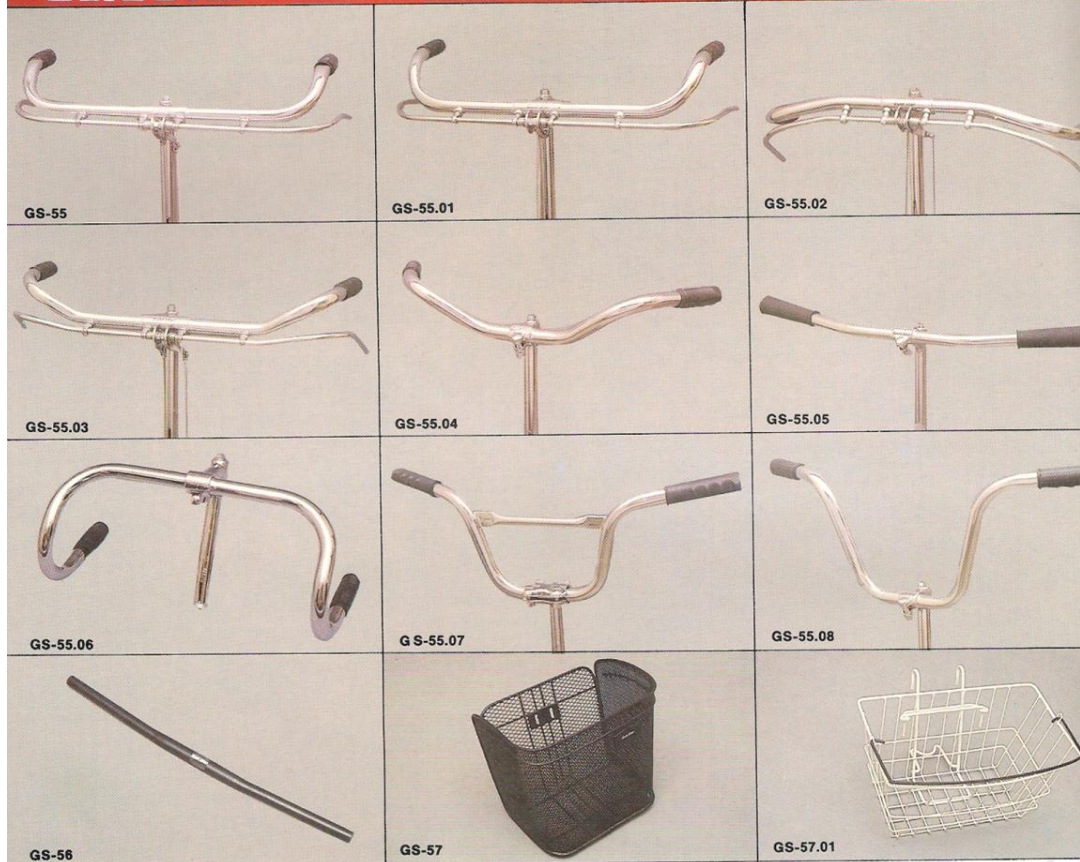

HANDLE BARS : Built of quality (ERW) tubes, ϕ 22.2 mm ($\frac{7}{8}$ "), suitable for roadster, sports, MTB & BMX Bicycles, BNCP/Powder coated finish.

GS-55 (PHILLIPS TYPE) : For side pull brakes, 75mm (3") tee-lug, double levers, Width - 17 $\frac{1}{4}$ ", Raise - 2 $\frac{1}{4}$ ", Stem Size - 7 $\frac{1}{2}$ "/9".

GS-55.01 (RALEIGH TYPE) : For centre pull brakes, 65mm tee-lug, double levers, Width - 17 $\frac{1}{4}$ ", Raise - 2 $\frac{1}{4}$ ", Stem Size - 7 $\frac{1}{4}$ "/6 $\frac{1}{4}$ ".

GS-55.02 (SEMI SPORTS TYPE) : North raised pattern with double levers, screw in stud attachment C.P. Available for 24" x 22" & 20" x 18" bicycles.

GS-55.03 (MEXICAN TYPE) : For side pull brakes, half race type bend, 75mm (3") tee-lug & double levers. Width - 17 $\frac{1}{4}$ ", Raise - 2 $\frac{1}{4}$ ", Stem Size - 7 $\frac{1}{2}$ ".

GS-55.04 (SLR TYPE) : Adjustable 1 $\frac{3}{8}$ " extension stem. Width - 19 $\frac{1}{4}$ ", Raise - 3 $\frac{1}{2}$ ", Stem Size - 7 $\frac{1}{2}$ ".

GS-55.05 (MTB TYPE) : For multispeed bicycles, Tapered bar & adjustable extension stem. Width - 580/600mm, Extension - 3 $\frac{1}{2}$ ", Stem Size - 7 $\frac{1}{2}$ ".

GS-55.06 (RACER TYPE) : Deep curved bar with adjustable & tapered stem size - 6 $\frac{1}{4}$ "/7 $\frac{1}{4}$ ", Width - 17 $\frac{1}{4}$ ".

GS-55.07 (BMX TYPE) : For BMX free style bicycles, Hi-Riser handle bar, adjustable extension stem & safety bar. Width : 21 $\frac{1}{4}$ ", Raise : 7 $\frac{3}{8}$ ", Stem Size : 7 $\frac{1}{2}$ ".

GS-55.08 (HI-RISER TYPE) : Raised pattern, adjustable 1 $\frac{3}{8}$ " tee-lug, Width - 21 $\frac{1}{4}$ ", Stem Size - 7 $\frac{1}{2}$ ".

GS-56 (MTB TYPE) : Taper handle bar for MTB/ATB, Black/CP finish. Width - 580/600mm or to order.

BASKETS

GS-57 : Steel wire basket, black plastic coating, with name plate.

GS-57.01 : Steel wire basket, white plastic coating, portable.



HANDLE STEMS Made of quality (ERW) steel tubes, mig welded finish black powder coated/BNCP.

GS-58 : For MTB bikes with Allen type expander bolt, 21/22mm tube, Length - 150/190mm extension 65, 80, 100mm Black/BNCP finish.

GS-58.01 : For MTB bikes with hexagonal type expander bolt.

GS-58.02 : For ATB/MTB bikes with brake wire hole, hexagonal/allen type expander bolt.

GS-58.03 : For deep drop racer handle bar, extension 80/60 mm length - 150mm.

GS-58.04 : For mountain bikes with Hexagonal Bolt.

GS-58.05 : For BMX handle bars, 35/37 mm extension with square cap, length - 135/150 MM.

GS-58.06 : For sports light roadster bikes, tube dia 22.2mm (7/8"), Length - 7 1/2".

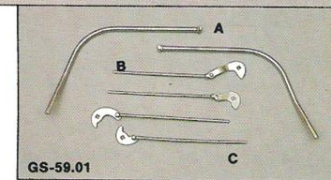

GS-59.01

HANDLE EXPANDER BOLT

GS-59 : Sizes : 5/16" (7.94mm)×26 TPI BSCY or 8mm×1mm pitch ISO-Metric threads. Length to order. Model A, B, C or D.

GS-59.01 : HANDLE PARTS - A : Handle levers left & right, B : Plunger rod for Phillips, C : Plunger rod for Raleigh.

GS-60 : LAMP BRACKETS Model A, B, or C.



MUDGUARDS : Made from CRCA strip, black enamelled/red/green/blue flamboyant colours or BNCP finish.

GS-61 (PHILLIPS TYPE) : For roadster bikes, deep dome shaped, single stay fastened. Width-55mm, Height-28.5mm, Wheel Sizes : 20/24/26/28".

GS-61.01 (SLR TYPE) : For sports & city bikes, centre ribbed section, round stays & plate fastening. Width-53mm, Height-24mm, Wheel sizes 26" & 20".

GS-61.02 (MTB/BALLOON TYPE) : U-shaped, round chain stays & plate fastening. Width-60mm, Height-23mm, Wheel sizes 26" & 24".

GS-61.03 (BMX TYPE) : U-shaped, round chain stays & plate fastening. Width-60mm, Height-23mm, Wheel sizes 20" & 16".

RIMS : Made from CRCA strip, seam welded, BNCP/Powder coated.

GS-62 (WESTRIC TYPE) : Sizes: 26" x 1 1/2" x 1 1/8", 16/20/24/26" x 1 1/8", 16/20/24/26" x 1.75", 16/20/24/26" x 2.125".

GS-62.01 (WESTRIC BALLOON TYPE) : Sizes : 26/28" x 1 1/2" x 2".

GS-62.02 (ENDRIC TYPE) : Sizes : 26" x 1 1/2" x 1 1/8", 26" x 1 1/2" x 2", 28" x 1 1/8" x 1 1/8", 16/20/24/26" x 1 1/8", 16/20/24/26" x 1.75", 16/20/24/26" x 2.125", 27" x 1 1/4".

GS-62.03 (ENDRIC TYPE) : Hook bead for MTB/ATB bikes, Sizes : 16/20/24/26" x 1.75", 26" x 1.90", 26" x 1.95", 16/20/24/26" x 2.125".

GS-62.04 (WESTWOOD TYPE) : Sizes : 24/26/28" x 1 1/2", 26" x 2" x 1 1/4", 26" x 2.125", 26" x 2", 16/20" x 1 1/8".

GS-63 (COTTON RIM TAPE) : Length : 2 Mtrs.

GS-64 (SPOKES) : Made from high carbon steel (EN-8) wire in galvanized/ZP finish with brass nipples.

WHEEL SIZES	LENGTH MM
28"	305-308
27"	300
26" x 1 1/2"	280
26" x 1 1/8"	285
24"	257
20"	197-216
16"	170

SWG	15G	14G	13G	12G	11G	10G
D mm	1.8	2.0	2.3	2.64	2.92	3.25

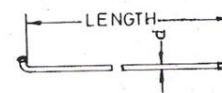

GS-65 (NIPPLE KEYS) : "A" two way 8 grooves, 10/10-12/12-14/14-15/15G. "B" one way 6 grooves, 10-12-14/14-15/15G. "C" one way 8 grooves, 9-10-11-12-13-14/14-15G.



BRAKES

GS-66 : PHILLIPS TYPE - suitable for roadster bicycles side pull type or PHILLIPS BALOON TYPE for wider tyres, side pull.

GS-67 : RALEIGH TYPE - suitable for roadster bikes, center pull.

CALIPER BRAKES

GS-68 : FOR MTB/BMX BIKES - side pull, high density steel made, solid levers, BNCP/Powder coated. Sizes : A-73, B-97, C-55, D-71MM approx.

GS-69 : FRENCH TYPE - complete with sheet metal levers, side pull, BNCP/Powder coated. Sizes : A-65, B-87, C-65, D-75MM approx. special mounting bracket.

GS-70 : FOR HI-RISER - complete with solid levers, side pull, BNCP/Powder coated. Sizes : A-65, B-87, C-65, D-75MM approx.

GS-71 : SLR TYPE - complete with sheet metal levers, side pull, Powder coated/BNCP. Sizes : A-63, B-82, C-74, D-70MM approx.

CANTILEVER BRAKES

GS-72 : Complete set low profile, adjuster vertically and horizontally, rigid steel arms sizes : A : 80-92MM, B : 22-28MM. Powder coated/BNCP.

GS-73 : Complete set low profile internal spring design, easy shoe adjustment. Sizes : A : 75-89MM, B : 20-30MM rigid steel arms powder coated/BNCP.

GS-74 : Complete set low profile internal spring design, adjuster vertically & horizontally, easy cable attachment, steel insert plastic moulded arms sizes : A : 80-92MM, B : 20-26MM. Sand/mat finish.

GS-75 : Handle levers A, B, C, D, E, F type.

GS-76 : Brake shoes A to O any type.

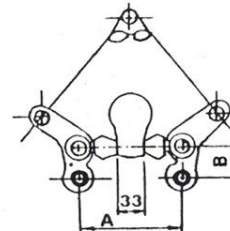

**Note: A. Pivot Dimms.
B. Reach.**

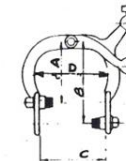



SADDLES

GS-78 : Leather top roadster, Rear latoo type springs, tripple wire base, size : 292×235×105mm.

GS-78.01 : Leather top roadster 90×2, Rear twisted coil springs, sizes : 260×210×73mm.

GS-78.02 : Leather top roadster 90×3, Rear twisted coil springs tripple wire base, sizes : 290×240×105mm.

GS-79 : Rexine top, rubber base steel frame, single coil springs, size : 235×216mm.

GS-79.01 : Rexine top, rubber base steel frame in two tone colours white blue/white & red size : 235×216mm.

GS-79.02 : Vinyl top, plastic base, mattress saddles, single coil springs, size : 245×205mm.

GS-80 : Touring saddles, for Demi baloon French bicycles, PVC cover top, sheet metal base, single coil spring sizes : 238×241mm.

SEAL PILLARS

GS-81 : Made of quality (ERW) steel tubes ZP/BNCP finish. "A" for BMX Diam : 22.2mm (7/8") Length 250mm & 280mm. "B" for BMX Diam : 25.4mm×22.2mm (7/8") Length : 325-380mm. "C" for roadster bicycles. Diam : 25.4mm (1")×22.2mm (7/8") Length to order.

SEAT CLIPS

GS-82 : A, B, C or D designs/Types for BMX, ATB, MTB, 90×3, 90×2, SLR, wittkop, scooter type saddles. Size 5/16" × 18 TPI WW threads.



SADDLES

- GS-83 : Plastic base, rubber foam vinyl top, colours to order.
- GS-83.01 : Plastic base, rubber foam vinyl top with double action coil springs.
- GS-83.02 : Plastic base, rubber foam vinyl top with two coil springs.
- GS-84 : A, B, C, D, E, F, for BMX, ATB & MTB, vinyl top, plastic base saddles. Colours to order.
- GS-85 : QUICK RELEASE SEAT PIN : Made of steel with black plastic coated lever. Diam 8mm or 5/16" Length 45-65 mm.

SADDLE PARTS

- GS-86 :
- A. Saddle twisted coil springs
- B, B-1. Saddle upper wire base.
- C. Saddle nose.
- D. Saddle front double loop spring.
- D-1. Saddle front loop spring.
- E. Saddle tripple base wire for 90x3
- E-1. Saddle tripple base wire for 90x2
- F. Saddle back plate fastner.

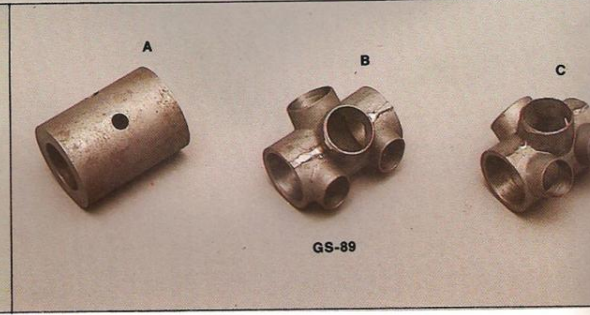
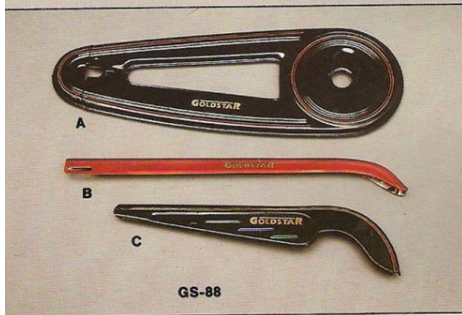
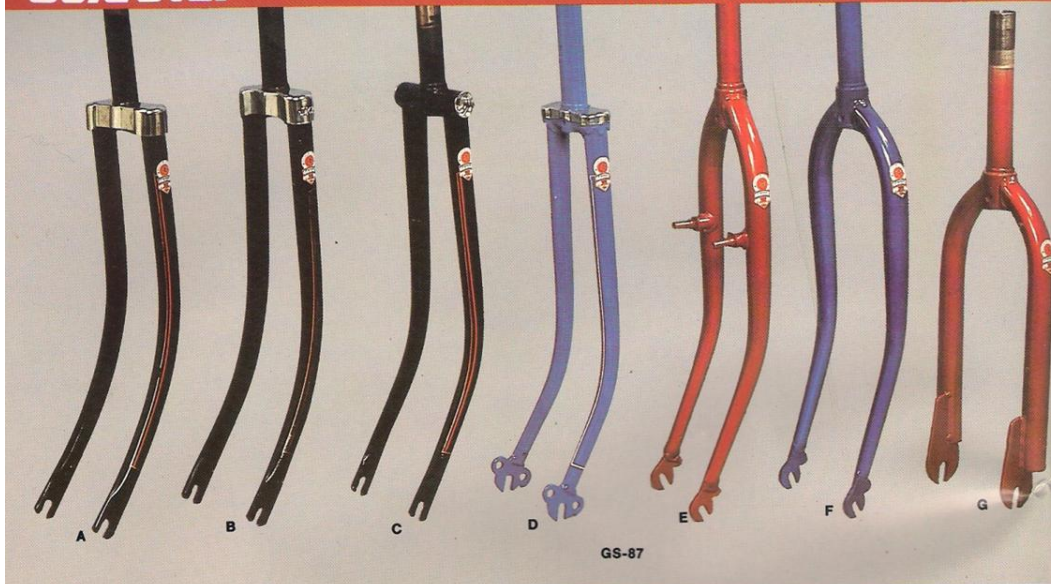

FRONT FORKS : Made from quality steel tubings, brazed column, threading-25.4mm (1") \times 24/26 TPI. Black enamelled or red/blue or green flamebouyant colours.

GS-87 A (BALOON TYPE) : For baloon tyres, 60mm clearance, box crown. Wheel sizes : 26" \times 2", 26" \times 2" \times 1 $\frac{1}{4}$ ".

GS-87 B (PHILLIPS TYPE) : For roadster bikes, box crown. Wheel sizes : 24/26/28" \times 1 $\frac{1}{2}$ ", 20" \times 1 $\frac{3}{8}$ ".

GS-87 C (RALEIGH TYPE) : For roadster bikes, tubular crown with BNCP thimbles. Wheel size : 28" \times 1 $\frac{1}{2}$ ".

GS-87 D (FRENCH/DEMI BALOON) : For light roadster bikes, box crown pressed sheet ends. Column threading-25mm \times 1mm pitch ISO-Metric. Wheel sizes : 26" \times 1 $\frac{1}{2}$ " \times 1 $\frac{1}{8}$ ", 28" \times 1 $\frac{1}{8}$ " \times 1 $\frac{1}{4}$ ".

GS-87 E (MTB TYPE) : For mountain bikes, Uni-crown, pressed/ forged ends, with Pivots. Wheel sizes : 24/26" \times 2.125"

GS-87 F (MTB TYPE) : Without Pivots.

GS-87 G (BMX/MTB TYPE) : Uni-crown, pressed sheet ends. Wheel sizes : 20/26" \times 2.125".

CHAIN COVERS

GS-88 : CHAIN COVERS : Model A, B, or C colour/finish to order.

B. B. SHELLS

GS-89A : B. B. SHELL : For ATB/BMX/Ranger bikes. Threads-24 TPI.

GS-89 B : B. B. SHELL : With oval pockets, 26 TPI.

GS-89 C : B. B. SHELL : With round pockets, 24 TPI.

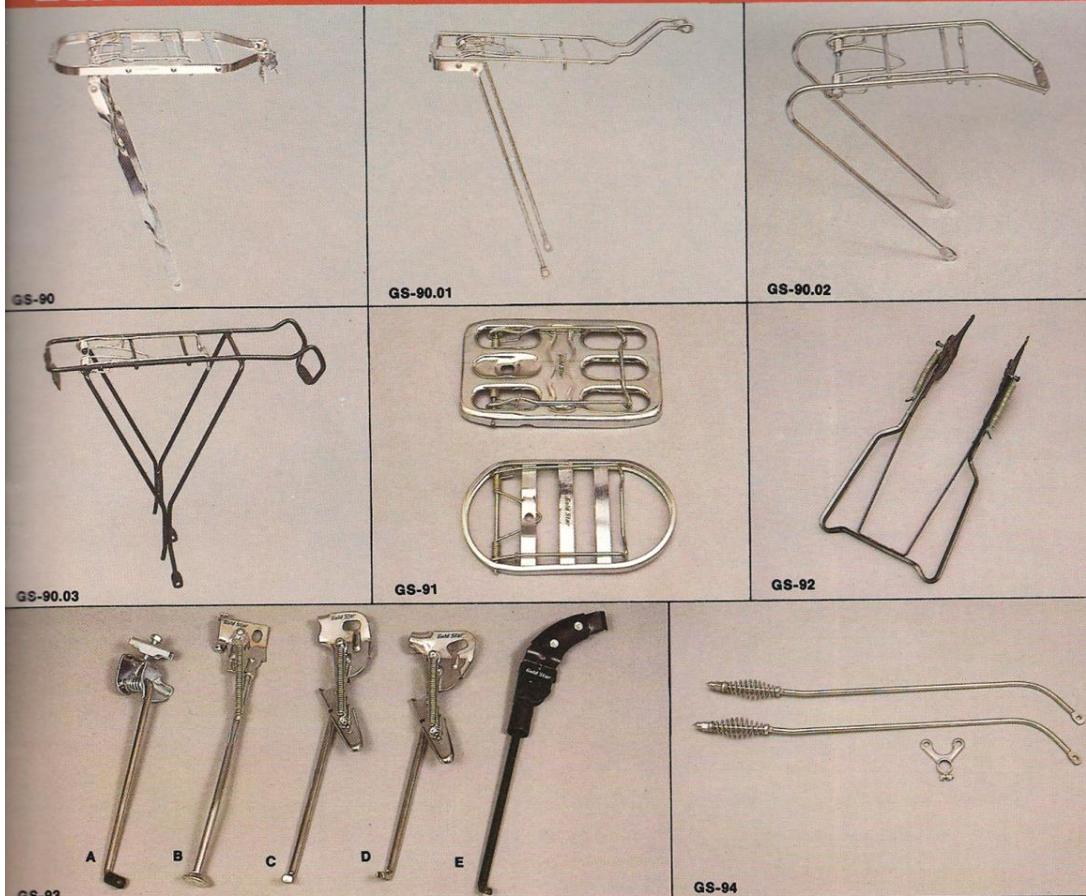

LUGGAGE CARRIERS

GS-90 (GENTS ROADSTER) : Channel type, BNCP/Black enamelled. Wheel sizes : 24/26/28"×1½".

GS-90.01 (SPORTS LIGHT ROADSTER) : Steel wire frame & stays, square/round back, BNCP finish. Wheel sizes : 28"×1½"×1¼", 26"×1½", 26"×2.125".

GS-90.02 (JUNIOR) : Steel wire frame & stays, BNCP. Wheel sizes : 16"×1.75".

GS-90.03 (MTB/ATB) : Steel wire frame & stays, Black/BNCP finish. Wheel sizes : 24/26"×2.125".

GS-91 : HANDLE CARRIERS - Model A or B.

STANDS

GS-92 (FULL ROADSTER) : For gents roadster bikes, channel type, kick-up lock with two/four springs, enamel finish.

GS-93 A (CENTRE STAND) : Wheel size : 26"×2.125".

GS-93 B (SIDE STAND BOLT TYPE) : With cup at bottom without lock. Wheel sizes : 26/28"×1½".

GS-93 C (GENTS ROADSTER) : With lock. Wheel sizes : 26/28"×1½".

GS-93 D (SPORTS LIGHT ROADSTER) : With lock. Wheel sizes : 26"×1½", 26"×2.125", 28"×1½"×1¼".

GS-93 E (PISTOL TYPE) : Steel rod, curved elevated frame. Wheel sizes : 24/26/28"×1½", black finish.

GS-94 FORK BUMPER

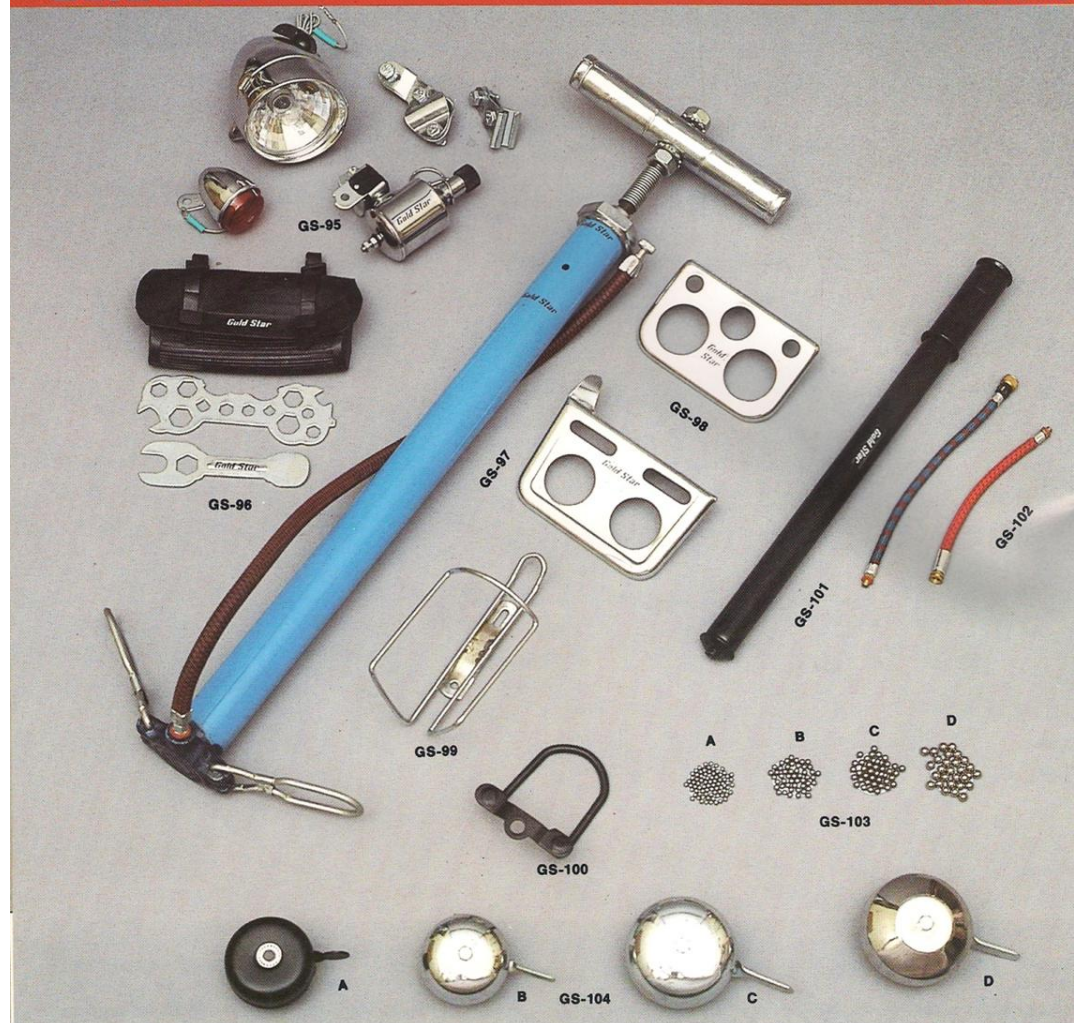

GS-95 : DYNAMO LAMP SETS - 12/6 volts, double bulb, square cut reflectors, complete with clamp, tail light & cord.

GS-96 : TOOL BAGS - With 13 hole spanner & tyre lever/screw driver.

GS-97 : FOOT PUMP - Heavy duty with pump connector for dunlop or American valves.

GS-98 : FOOT REST - Model "A" or "B" with 3/8" hole to be fitted with hub axles.

GS-99 : STEEL WIRE CAGE - For water bottle.

GS-100 : DERALLIUR PROTECTOR - In small, medium & large sizes.

GS-101 : FRAME PUMP - Steel barrel, with 6" or 8" braided pump connector. Dunlop or American Valve. Size : 1" x 15" L.

GS-102 : PUMP CONNECTORS - For frame pump, braided dunlop/ American Valves. Sizes : 6" & 8".

GS-103 : STEEL BALL - Carbon/chrome steel balls, in pouch or bulk packing sizes : "A" 3.17mm (1/8") for fork fittings Ph/Type & Freewheels, "B" 3.97mm (5/32") for fork fittings RL/Type & Pedals, "C" 4.76mm (3/16") for front Hubs thin barrel, 5.55mm (7/32") for Rear Hubs, "D" 6.35mm (1/4") for front & rear hubs Ph/Type & B.B. Fittings.

GS-104 : BELLS : "A" Steel top, gear type, piano round, Black/BNCP size 2 1/4", "B" steel dome, bolt type, BNCP, size 2 1/4", "C" bolt type, size 3", "D" Pyramid shape, steel dome, bolt type, BNCP, size 3".

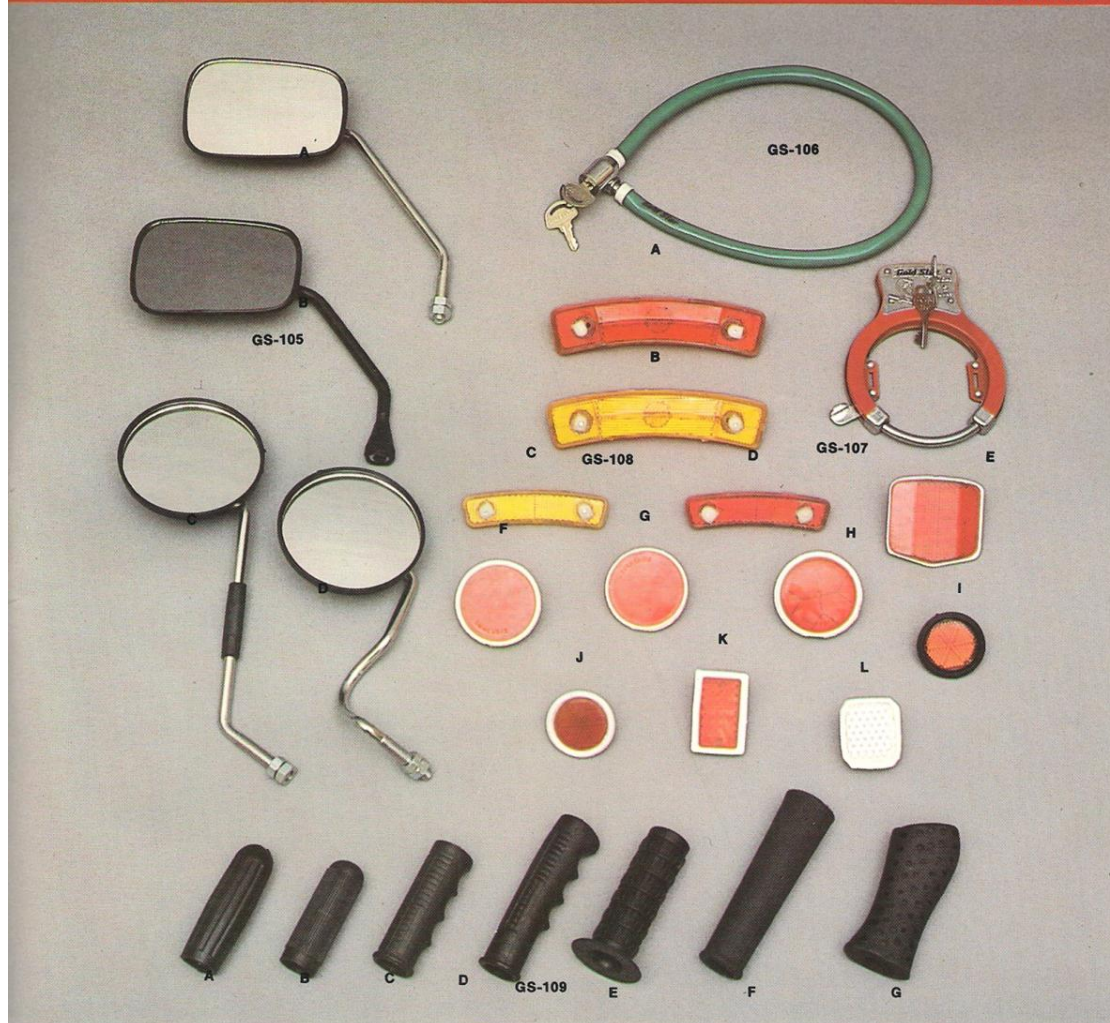

GS-105 : REAR VIEW MIRRORS - A, B, C or D.

GS-106 : WIRE LOCK - Cylinder lock with two keys, cable dia 5mm, covered with assorted colour PVC sleeves. Sizes : 18", 20" & 24".

GS-107 : RING LOCK - For roadster bicycles, 4 1/8" diameter, clip fastening assorted colour enamel finish.

GS-108 : REFLECTORS - A, B, C, D spoke reflectors, E lamp Bracket reflector, F side reflector, G, H, I, J, K, L rear mudguard reflectors.

GS-109 : HANDLE GRIPS - A, B, C, D, E, F & G.

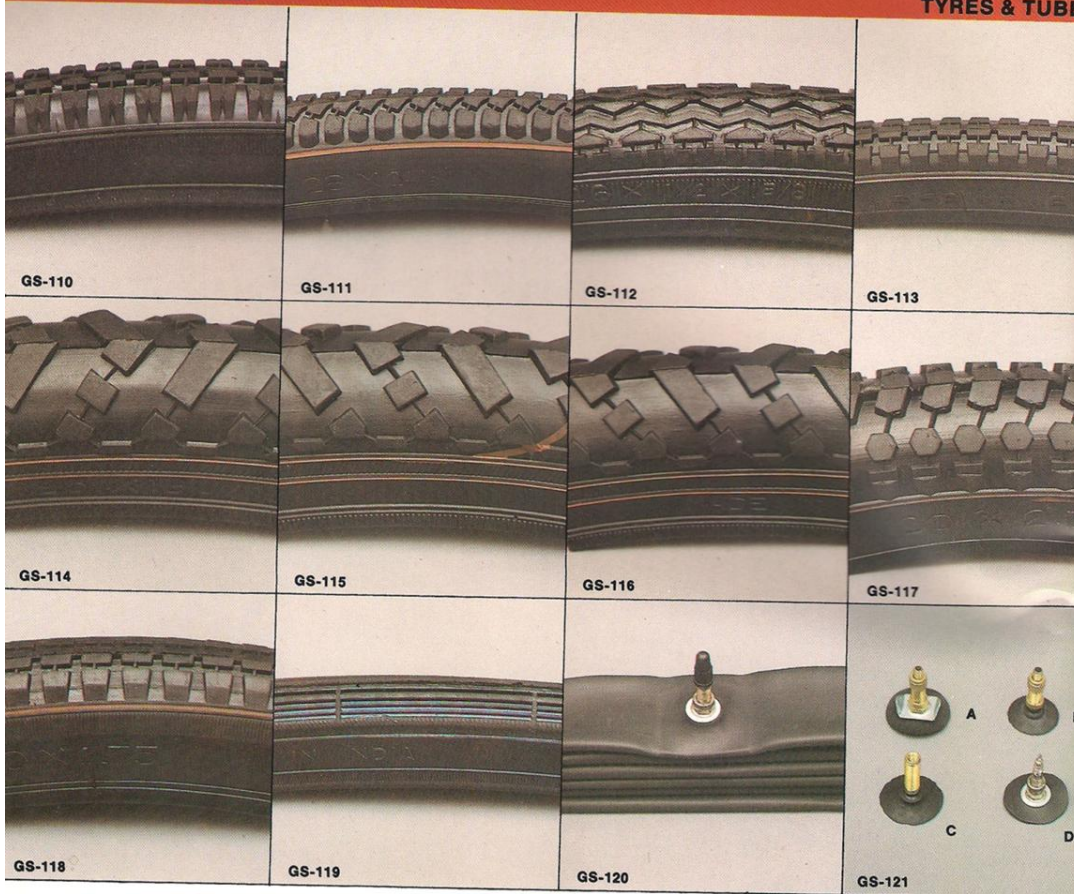

TYRES

- GS-110 : 28"×1½" (40×635)
- GS-111 : 26"×1½" (40×584)
- GS-112 : 26"×1½"×1¼" (44-584)
- GS-113 : 26"×1¾" (37-590)
- GS-114 : 26"×1.90"/1.95"
- GS-115 : 24"×1.90"/1.95"
- GS-116 : 24"×2.125" (57-507)
- GS-117 : 20"×2.125" (57-406)
- GS-118 : 20"×1.75" (47-406)
- GS-119 : 27"×1¼" (32-630)
- GS-120 : INNER TUBE - size and valve to order.
- GS-121 : TUBE-VALVES - A, B, C & D.
- FOR ROADSTER BIKES : 28"×1½" (40-635), 26"×1½" (40-584), 20"×1.75 (47-406)
- FOR DEMIBALLOON (FRENCH) BIKES : 26"×1½"×1¼" (44-584), 26"×1¾" (37-590), 28"×1½" (40-635)



- FOR BMX BIKES : 20"×2.125 (57-406), 16"×2.125" (57-305), 24"×2.125" (57-507), 20"×1.75" (47-406)
- FOR CITY BIKES : 28"×1¾"×1¼" (32-622), 28"×1¾"×1½" (28-622)
- FOR RACING BIKES : 27"×1¼" (32-630), 28"×1½" (40-635)



GS-501 : Chrome Silencer Moby / Silencioso Cromado Moby/
Echappement Chrome Moby.

GS-502 : Silencer Moby Blue-White/Silencioso Moby Nuevo Modelo/
Echappement Moby Blue-Blanc.

GS-503 : Silencer Peugeot Black-White/Silencioso Peugeot/
Echappement Peugeot Noir Blanc

GS-504 : Silencer Peugeot 50/Silencioso Peugeot 50/Echappement
Peugeot 50

GS-505 : Complete Pulley with sprocket of 11, 12, or 13 Teeth./Polea
Completa Moby 11, 12 o 13Z./Poulie complete Moby 11, 12, oU 13Z.

GS-506 : Complete Pulley Peugeot 11, 12, or 13 Teeth./Polea Completa
Peugeot 11, 12 o 13Z./Poulie complete Peugeot 11, 12, oU 13Z.

GS-507 : Complete Pulley Peugeot old Model.

GS-508 : Clutch Cover PGT.

GS-509 : Axle-89/Axe-89 MBK.

GS-510 : Axle-88/Axe-88 MBK.

GS-511 : Hub Axles 10×186mm set of 7 Pcs.

GS-512 : Hub Axles 12×200mm set of 9 Pcs.

GS-513 : Hub Axles 11×200mm set of 9 Pcs.

GS-514 : Hub Axles 11×180mm set of 9 Pcs.

GS-515 : Hub Axles 11×160mm set of 9 Pcs.

GS-516 : Hub Axles 11×145mm set of 15 Pcs.

GS-517 : Shock Absorbers with Exterior Spring PGT/Amortisseur
Ressort A Vue PGT/Amortiguador muelle visto PGT. 295/310 or 335mm.

GS-518 : Shock Absorbers MBK 275 or 280mm.



GS-519 : PGT - Old model - 11T, 12T & 13 teeth.

GS-520 : PGT - New model - 11T, 12T & 13 teeth.

GS-521 : MBK - 11T, 12T & 13 teeth.

GS-522 : SPX - 10T, 11T, 12T & 13 teeth.

GS-523, GS-524 & GS-525 : Gear box sprockets for 100-CC bikes.
Design & teeth to order.

GS-526 : Pulley bearing PGT/MBK

GS-527 : Piston/Connecting rod small end bearing MBK.

GS-528 : Piston/Connecting rod small end bearing PGT.

GS-529 : Clutch bearing MBK.

GS-530 : Connecting rod/Crank bearing small end PGT.

GS-531 : Connecting rod/Crank bearing big end MBK.

GS-532 : Clutch bearing PGT/Douille A Aiguilles

GS-533 : Bague MBK.

GS-534 : Silent Block.

GS-535 : Clutch Spring Washer PGT.

GS-536 : Clutch Spring Washer MBK.

GS-537 : Chain Tensioner Plastic PGT.

GS-538 : Chain Tensioner Plastic MBK.

GS-539 : Engine Patti MBK.

GS-540 : Engine Patti MBK.

GS-541 : Belt Cover.

GS-542 : Locking stop Mobty.

GS-543 : Chain Tensioner Moby/Peugeot.

GS-544 : Engine Patti PGT.

GS-545 : Mounting Clamp PGT.

GS-546 : Silencer Bracket.



GS-547 : Rear sprocket 48/52/54 or 56 teeth PGT.

GS-548 : Rear sprocket 44/48 or 54 teeth MBK.

GS-549 : Rear sprocket 42/44 or 45 teeth PGT.

GS-550 : Rear sprocket 44 teeth MBK new model.

GS-551 : Aluminium Cover.

GS-552 : Pedals solid rubber. Thread 14X1.25mm pitch.

GS-553 : Pedals Union type.

GS-554 : Foot rests. Model A, B, C or D.

GS-555 : Cranks D & G. MBK 165mm/PGT 170mm.

GS-556 : Chainwheels & Cranks 32T X 165mm/32T X 170mm. MBK

GS-557 : Central Axle with sprocket 30T.

GS-558 : Central Axle with sprocket 28T MBK.

GS-559 : Central Axle with sprocket 32T. Model-P-50

GS-560 : Chains 1/2" X 1/8".

GS-561 : Chains 1/2" X 3/16" light or heavy duty No. of links 102/106/108/112 or 114.

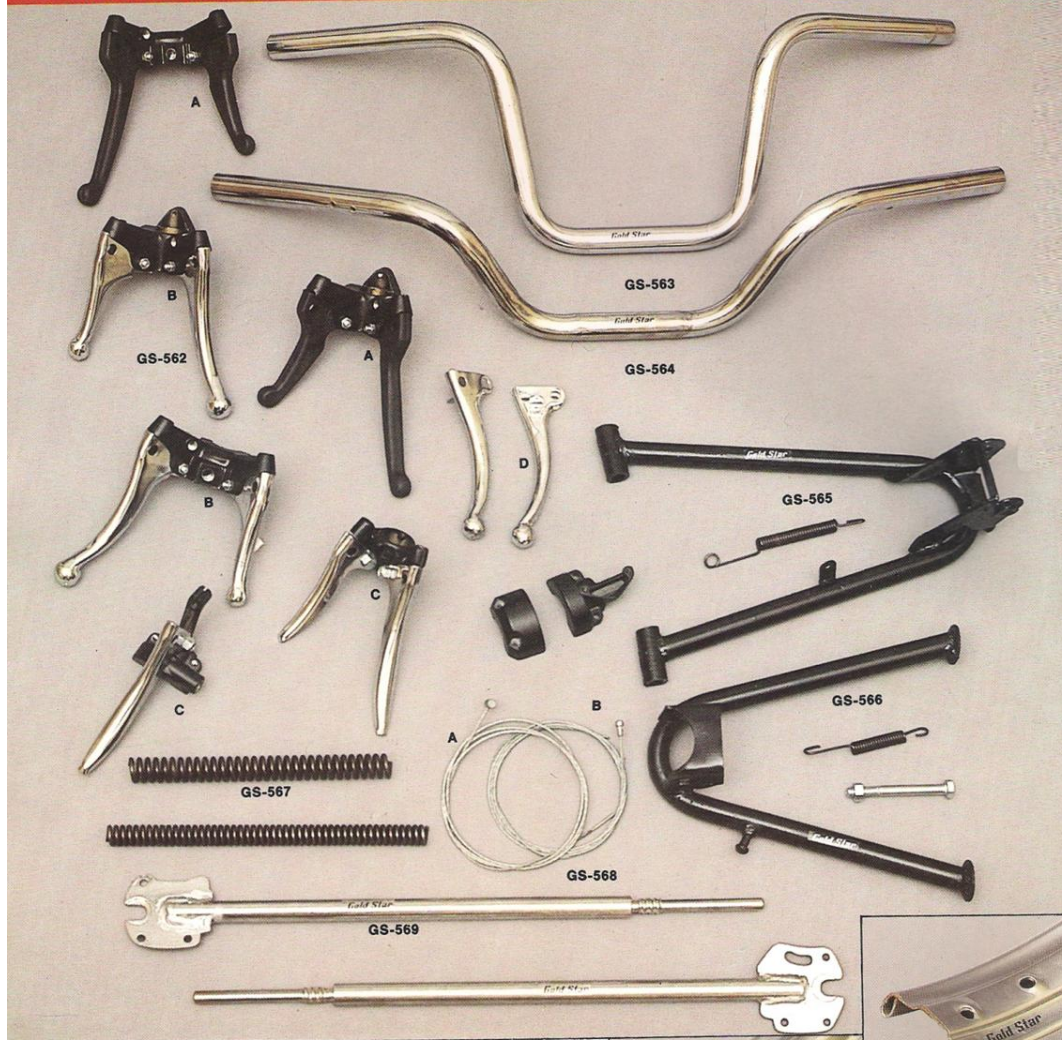

- GS-562 : Handle levers. Model A, B, C or D.
- GS-563 : Handle Bars MBK.
- GS-564 : Handle Bars PGT.
- GS-565 : Center stand PGT.
- GS-566 : Center stand MBK.
- GS-567 : Fork springs MBK/PGT.
- GS-568 : Cable wires. Model A or B, length to order.
- GS-569 : Front stem forks MBK.

RIMS

- GS-570 : ENGLISH TYPE - 16"×2.50", 17"×2.50", 18"×2.50", 19"×2.50" & 20"×2.50"
- GS-571 : FRENCH TYPE - 16"×2.50", 17"×2.50", 18"×2.50", 19"×2.50" & 20"×2.50"
- GS-572 : SLEEK - 16"×2.0", 17"×2.0", 18"×2.0", 19"×2.0" & 20"×2"×1¾"



